



AMC CERRADURAS

CATÁLOGO

CIERRES Y CERRADURAS



Cerradura univ.

Art. 001



Cierre "T"

Art. 017T



Cierre □

Art. 017□



Cierre "E"

Art. 019E



Cierre "D"

Art. 019D



Cierre "moño"

Art. 019M



Cierre plástico

Art. 027



Cierre DIN

Art. 032



Pomela

Art. 033

CIERRES Y CERRADURAS



"T" con base plástica

Art. 053



Cierre base plástica con asidero con o sin llave

Art. 055



Muletilla 1/4 c/ llave

Art. 060



Muletilla 1/4 s/ llave

Art. 060



Manija plástica regulable

Art. 057



Pomela regulable

Art. 042



Cerradura univ.

Art. 001

- Material: Zamak.
- Frente redondo.
- Acabado zincado/niquelado/pintura epoxi.
- Incluye 2 llaves.

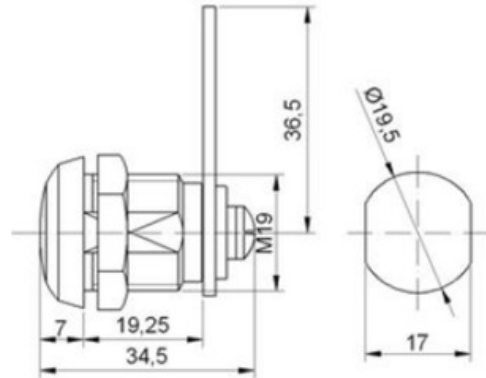

Cierre "T"

Art. 017T

- Material: Zamak/plástico-zamak/plástico.
- Frente redondo.
- Acabado zincado/niquelado/pintura epoxi.

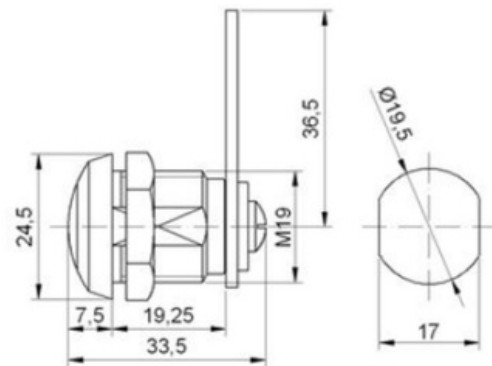



Cierre □

Art. 017□

- Material: Zamak.
- Frente redondo.
- Acabado niquelado.
- Incluye o-ring interno y externo.
- Manija de apertura opcional.

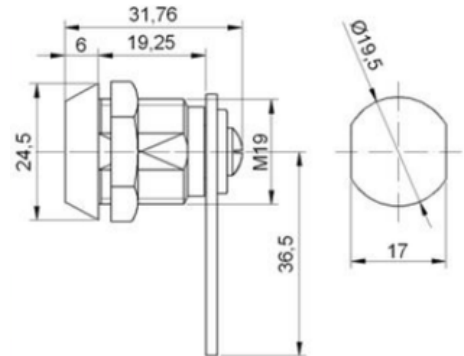

Cierre "E"

Art. 019E

- Material: Zamak/plástico-zamak.
- Acabado zincado/niquelado/pintura epoxi.
- Opcional o-ring interno y externo.

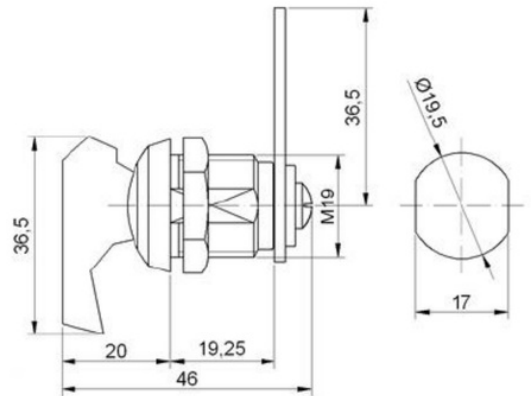

Cierre "D"

Art. 019D

- Material: Zamak/plástico-zamak.
- Acabado zincado/niquelado/pintura epoxi.
- Opcional o-ring interno y externo.

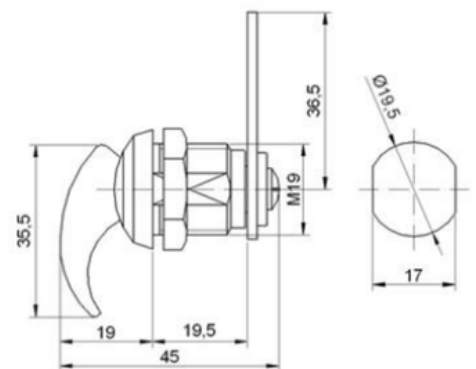



Cierre "moño"

Art. 019M

- Material: Zamak/plástico-zamak.
- Acabado zincado/niquelado/pintura epoxi.
- Opcional o-ring interno y externo.

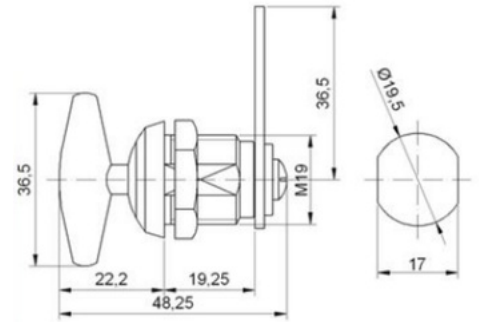

Cierre plástico

Art. 027

- Material: Zamak y manija de plástico.
- Opcional o-ring interno y externo.

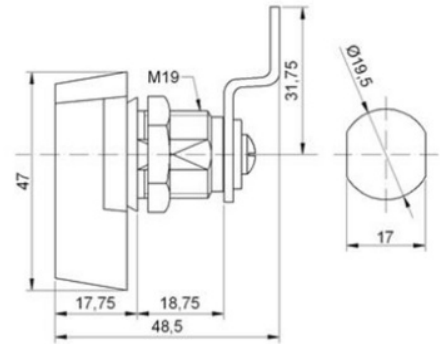

Cierre DIN

Art. 032

- Material: Zamak.
- Opcional o-ring interno y externo.
- Manija de apertura opcional.

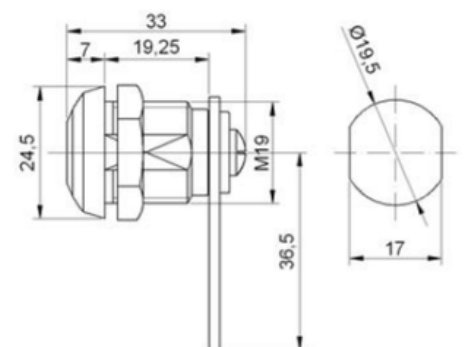



Pomela

Art. 033

- Material: Cuerpo de Zamak y manija de ABS.
- Apertura 180° (media vuelta).

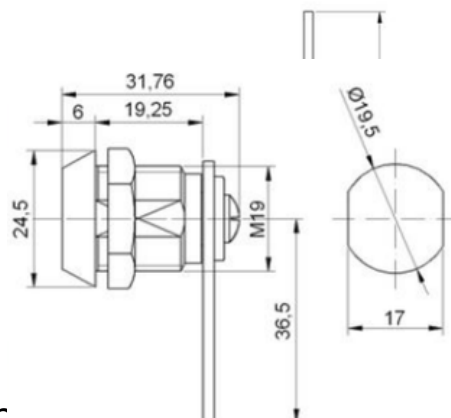

Pomela regulable

Art. 042

- Material: Zamak y m
- Lengüeta regulable.

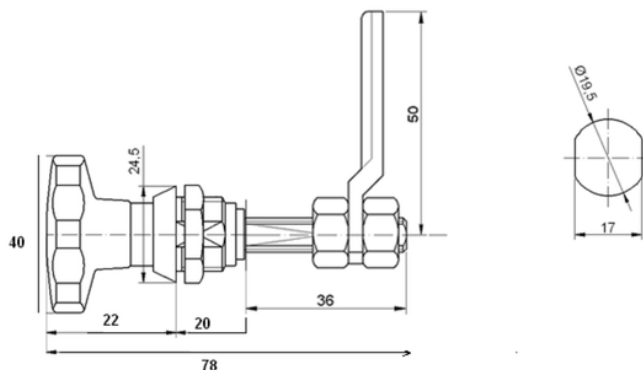

Cierre \triangle

Art. 045

- Material: Zamak.
- Acabado niquelado.
- Opcional llave plástica para apertura.

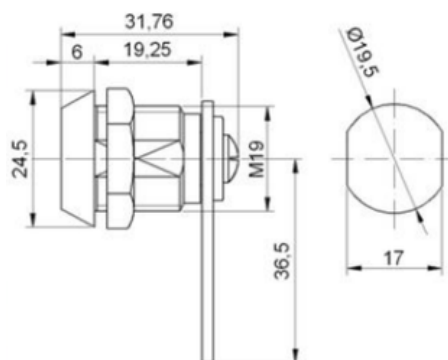



"T" con base plástica

Art. 053

- Material: Cuerpo de Zamak y manija de nylon.
- Acabado zincado o niquelado.
- Opcional cierre "T" para apertura con destornillador, manijas ("D", "E", "moño"), o cerradura con llave.



Cierre base plástica con asidero con o sin llave

Art. 055

- Material: Cuerpo de Zamak y manija de nylon.
- Acabado zincado o niquelado.
- Opcional cierre "T" para apertura con destornillador, manijas ("D", "E", "moño"), o cerradura con llave.



Muletilla 1/4 c/ llave

Art. 060

- Material: Zamak.
- Acabado pintura epoxi negra.
- Incluye dos llaves.
- Lengüeta regulable.

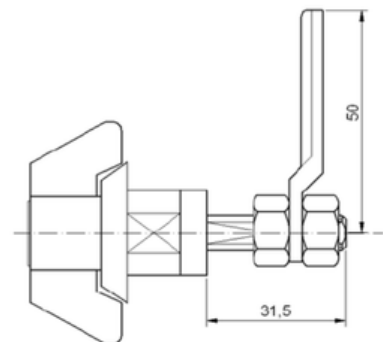



Muletilla 1/4 s/ llave

Art. 060

- Material: Zamak.
- Acabado pintura epoxi negra.
- Lengüeta regulable.

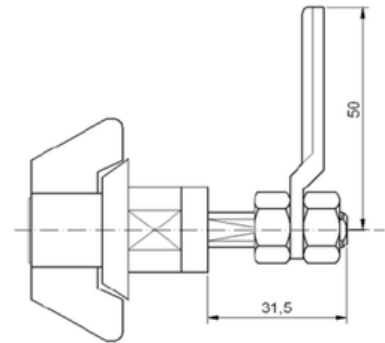

Manija plástica regulable

Art. 057

- Material: Zamak y manija de nylon.
- Lengüeta regulable.
- Incluye o-ring interno y externo.

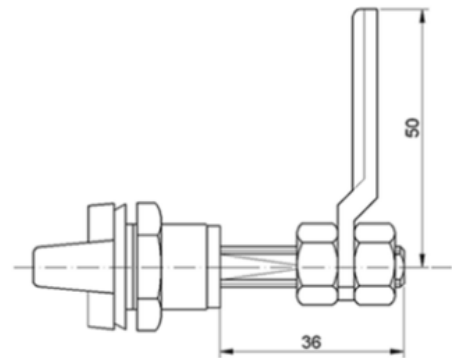

MANIJONES TIRAPUERTAS



Art. 020/21

- Acabado: Extremos metálicos con acabado cromado o pintura epoxi.

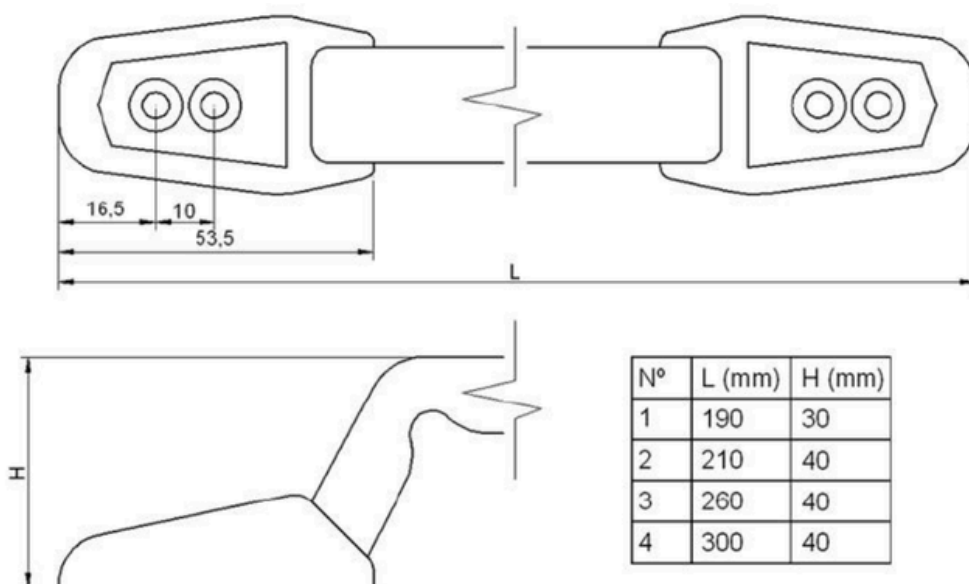

MANIJAS



Manija "T" con llave

Art. 030 con llave / sin llave Art. 031

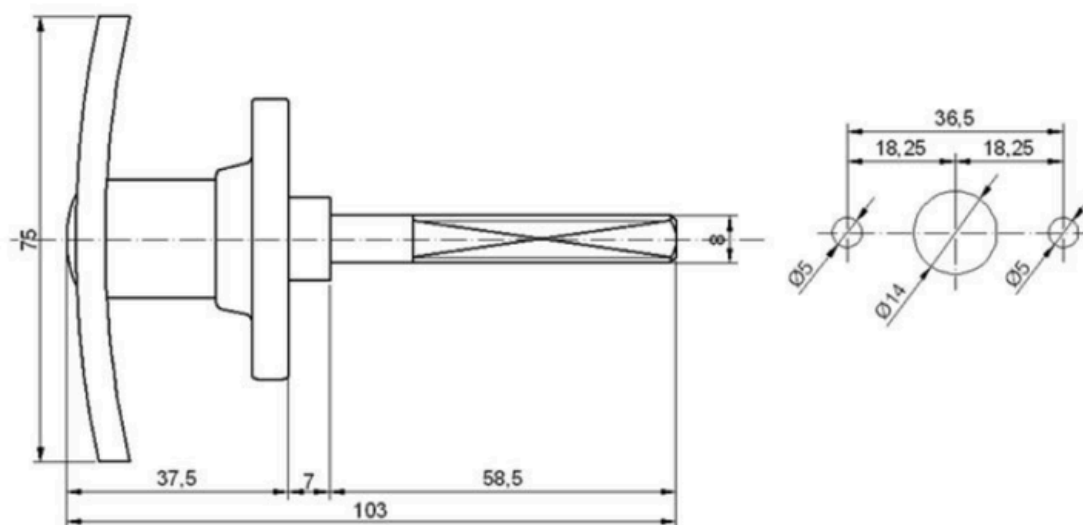



Manija "L"

Art. 026

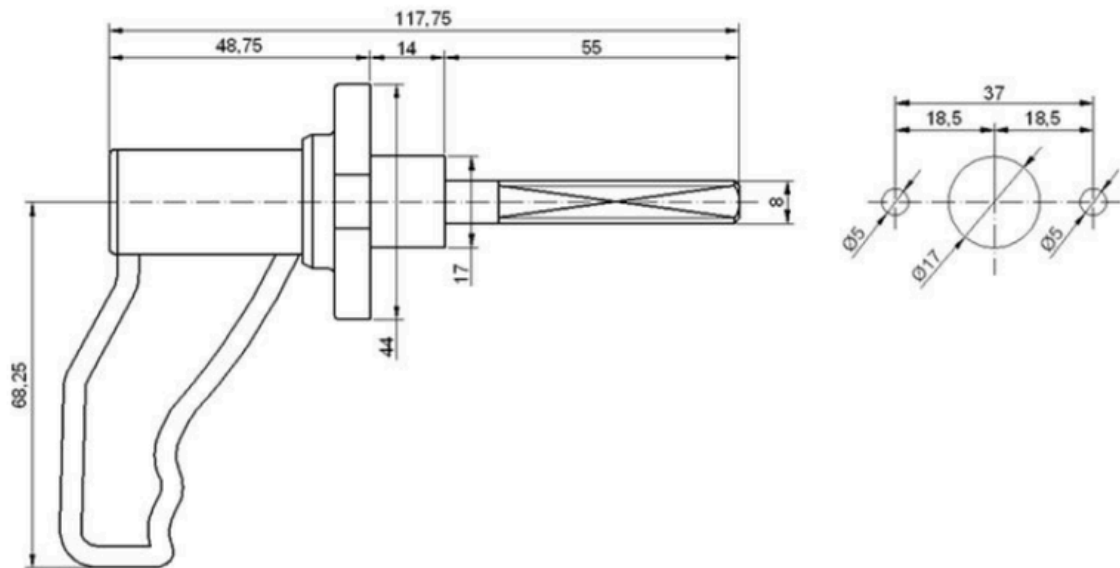

TRABAS

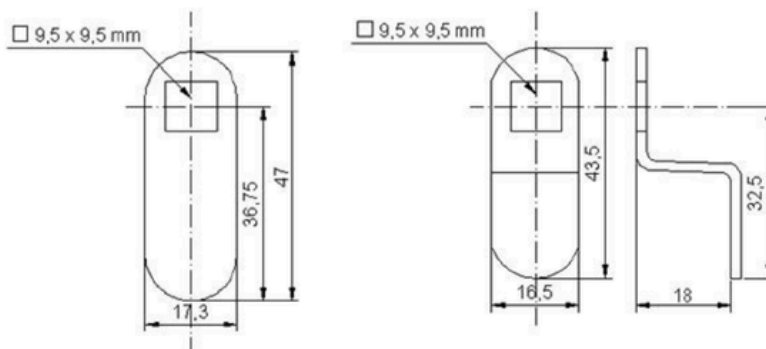

Traba A

Traba B

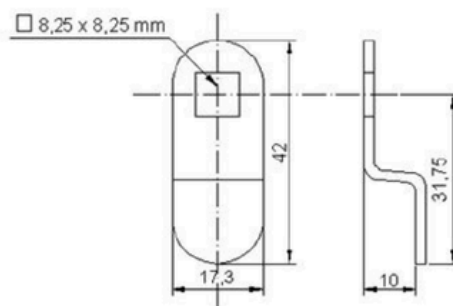

- Consulte por medidas disponibles.

CONTACTO



ventas@amc-cerraduras.com.ar



+54 11-7366-2106



4729-6148

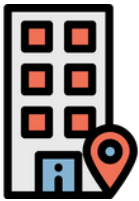

**Rawson 2774, José León Suárez,
Buenos Aires**